



BBS BATTERY BACKUP SYSTEM FOR POL LED OBSTRUCTION LIGHTS

POL LED Lights are Tested & Certified FAA L-810 by Intertek Testing Service (ETL)
per FAA AC 150/5345-43F & Engineering Brief No. 67 (Nov 2004)
Complies with ICAO Annex 14 Low Intensity Types A (10 cd) & B (32 cd)

The POL POINTSPEC series of red LED aviation obstruction lights presents the highest grade technical features and the most options available in the industry. POL steady-burning obstruction lights are used to mark tall structures that present hazards to air navigation. At night, these lights warn pilots when installed in accordance with FAA AC 70/7460-1 and applicable FCC and ICAO rules. The PPC photoelectric controller provides automatic activation at dusk in accordance with FAA specifications. All POINTSPEC LED POL's include corrosion protection, ground wire(s), stainless steel hardware, & tether. Note: FAA certified with FAA lamp number 281 Accepts any commercial AC power between 90V and 260V. Upon failure of the AC power, the BBS switches to battery power for up to three nights of unattended operation (based on a single POL or double POL with transfer). Automatic battery charging under normal AC power.

Choose the POL LED model from catalog file OL-1.9.0 Note: Must be a -3F or -3A model with option -P

BBS-60500-(serial number)

BBS Battery & Control Unit

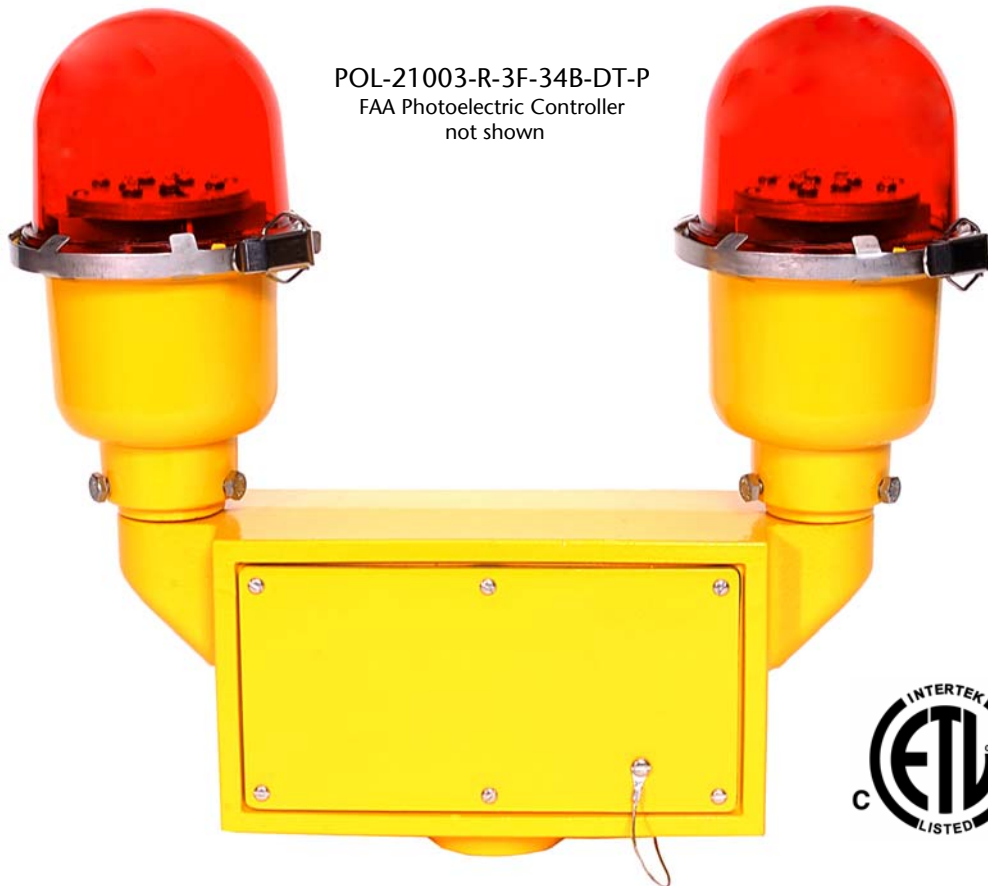

POL-21003-R-3F-34B-DT-P
FAA Photoelectric Controller
not shown



POINT OBSTRUCTION LIGHTS POL LED WITH BATTERY BACKUP SYSTEM

SPECIFICATIONS

POL LED OBSTRUCTION LIGHT & BATTERY BACKUP SYSTEM

The red LED lighted aviation obstruction light shall fully comply with (specify: FAA L-810 & ICAO type B or ICAO type A). The light shall operate as a single obstruction light on commercial AC power and, upon failure of the commercial power, shall transfer automatically to a backup battery power supply with the capacity to operate the light normally for three (3) nights before resumption of the AC power. In both modes, the obstruction light shall be switched on at night and off during the day at the FAA specified light levels by an FAA photoelectric controller prewired to the light fixture.

The BBS unit operates on normal commercial power and shall accept a universal input line voltage that may vary within the range of 90 VAC to 260 VAC. Within the preceding ranges, the output shall be converted from AC to a controlled, stabilized 12 VDC to the POL light. All light fixture leads shall be clearly tagged for connection to the BBS Battery & Control Unit.

The POL DC light head shall have passed the FAA certification tests: the constant high temperature test to +130 deg F (+55 deg C) and the constant low temperature test to -67 deg F (-55 deg C) conducted in accordance with US MILSTD-810E, Method 501.3, Procedure II; the wind-blown rain test conducted in accordance with US MIL-STD-810E, Method 506.3, Procedure I; and the humidity test shall be in accordance with US MIL-STD-810E, Method 507.3, Procedure I. The complete test regime shall exceed the requirements of NEMA 4X and IP65. The light head shall be powdercoat painted aviation red for corrosion resistance certified by the manufacturer to comply with the US Military Standard Salt Fog Test conducted per MIL-STD-810E, Method 509.3, Procedure I.

Important! The POL selected must be a 12 VDC unit and must include option -P FAA Photoelectric Controller.

The clear lens shall be strong soda lime glass and permit full light transmission. The lens shall be smooth and rounded to reduce the adhesion of dirt, ice and snow.

The red emitting LED's shall meet the chromaticity requirements of US MIL-C-25050. The high output LED's shall not exceed eight (8) in number and shall be the latest technology providing uniform light output over the range required by the governing standard. The LED average life shall exceed 100,000 hours.

The LED's shall be soldered in a factory set position to insure consistent light output. Wire mounted raised LED's that can be bent out of position shall be unacceptable and cause for rejection. The power supply board shall include short circuit and open circuit protection and the unit shall be protected from line surges by metal oxide varistors (MOV's). There shall be a clear design element for the dissipation of LED heat to insure the LED's do not fail prematurely.

The wiring access cover shall be gasketed to be watertight, shall have captive screws and shall be secured to the unit with a tether. The fixture body and cover shall be powdercoat painted aviation yellow for corrosion resistance certified by the manufacturer to comply with the US Military Standard Salt Fog Test conducted per MIL-STD-810E, Method 509.3, Procedure I. The cover tether and all hardware shall be stainless steel.

Battery charging is to be automatic and included in the POL BBS Battery & Control Unit. All components shall tolerate the above specified universal voltage range. Wiring from the unit to the fixture shall be provided by others.

The enclosure shall be wall-mounted steel industrial grade rated NEMA 4 watertight and NEMA 12 dust tight with door clamps and shall be padlockable. The unit shall contain the deep cycle rechargeable battery, 12 VDC power supply and automatic charger.

There shall be a momentary push-to-test switch on the door. There is no loss of power alarm as loss of commercial power is apparent. There shall be a door mounted green Power On pilot light meaning the commercial AC power is present at the unit and this light will go out when the system is operating on battery backup after loss of AC power. Alarm functions, if any, based on the POL model selected shall operate in both AC and battery modes.

The POL Battery Backup System shall consist of the POL-21003-R-3F-34B-xx-P light fixture assembly with the BBS-60500-xxxxxxx Battery & Control Unit manufactured by Point Lighting Corporation.

POINT LIGHTING CORPORATION

Mail: P.O. Box 686, Simsbury, CT 06070

Tel 01 860.243.0600

email: PointLighting@earthlink.net

Plant: West Dudley Town Rd, Bloomfield, CT

USA

Fax 01 860.243.0665

website: www.PointLighting.com

**BBS BATTERY BACKUP SYSTEM
FOR
POL LED OBSTRUCTION LIGHTS**

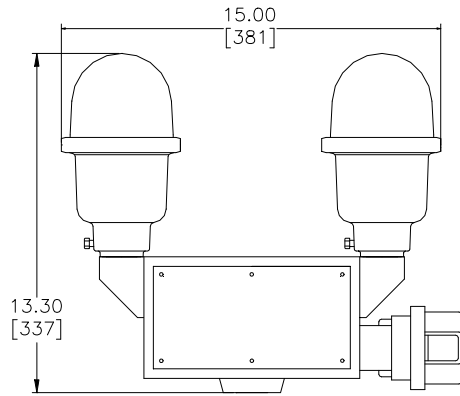

POL-21003-R-3F-34B-DT-P
TYPICAL 12VDC POL WITH OPTION -P

BBS-60500-(SERIAL NUMBER)
BBS BATTERY AND CONTROL UNIT

